



RAYSTAR

曜凌光電股份有限公司

Web: www.raystar-optronics.com E-mail: sales@raystar-optronics.com

RFY1230B-AWH-LNN

SPECIFICATION

General Specifications

- Size: 12.3 inch
 - Pixel Number: 1920 RGB (H) x 720(V) pixel
 - Module dimension: 308.1(H) x 130.0(V) x 7.6 mm
 - Active Area: 292.032(H) x 109.512(V) mm
 - Pixel Pitch: 0.1521(H) x 0.1521 (V) mm
 - LCD type: TFT, Normally Black, Transmissive
 - Viewing Angle: 85/85/85/85
 - Backlight Type: LED ,Normally White
 - Touch Panel: Without Touch Panel
 - TFT Interface: 2ch-LVDS
 - Surface: Anti-Glare
- *Color tone slight changed by temperature and driving voltage.

Interface

1. TFT LCD MODULE

FPC connector is used for electronics interface.

AORORA F31L-1A7H1-21050 , 50PIN

Pin no.	Symbol	Function
1	GND	Power Ground
2	NC	No connector
3	VCC	Digital Power
4	VCC	Digital Power
5	GND	Power Ground
6	GND	Power Ground
7	NC	No connector
8	NC	No connector
9	GND	Power Ground
10	ORXIN0-	Odd pixel negative LVDS differential clock input
11	ORXIN0+	Odd pixel positive LVDS differential clock input
12	ORXIN1-	Odd pixel negative LVDS differential clock input
13	ORXIN1+	Odd pixel positive LVDS differential clock input
14	ORXIN2-	Odd pixel negative LVDS differential clock input
15	ORXIN2+	Odd pixel positive LVDS differential clock input
16	ORXCLKIN-	Odd pixel negative LVDS differential clock input
17	ORXCLKIN+	Odd pixel positive LVDS differential clock input
18	ORXIN3-	Odd pixel negative LVDS differential clock input
19	ORXIN3+	Odd pixel positive LVDS differential clock input
20	ERXIN0-	Even pixel negative LVDS differential clock input
21	ERXIN0+	Even pixel positive LVDS differential clock input
22	ERXIN1-	Even pixel negative LVDS differential clock input
23	ERXIN1+	Even pixel positive LVDS differential clock input
24	ERXIN2-	Even pixel negative LVDS differential clock input
25	ERXIN2+	Even pixel positive LVDS differential clock input
26	ERXCLKIN-	Even pixel negative LVDS differential clock input
27	ERXCLKIN+	Even pixel positive LVDS differential clock input
28	ERXIN3-	Even pixel negative LVDS differential clock input
29	ERXIN3+	Even pixel positive LVDS differential clock input

30	GND	Power Ground
31	NC	No connector
32	RESETB	Global reset pin, active low.
33	STBYB	Standby mode, active low.
34	CA3	Cascade signal pin. Abnormal signal detection indicator. Combine HV/DE/Clock/STV/UEP detection result.
35	NC	No connector(Serial interface clock input.SCL)
36	NC	No connector(Serial interface data input/output.CDA)
37	NC	No connector(Serial interface chip enable.CSB)
38	GND	Power Ground
39	GND	Power Ground
40	NC	No connector
41	LEDA	LED power (Anode)
42	LEDA	LED power (Anode)
43	LEDA	LED power (Anode)
44	NC	No connector
45	LEDK1	Cathode 1
46	LEDK2	Cathode 2
47	LEDK3	Cathode 3
48	LEDK4	Cathode 4
49	NTC_A	Thermistor input
50	NTC_K	Thermistor Feedback

Note: NTC Parts: Murata NCP18XH103F03RB

Contour Drawing

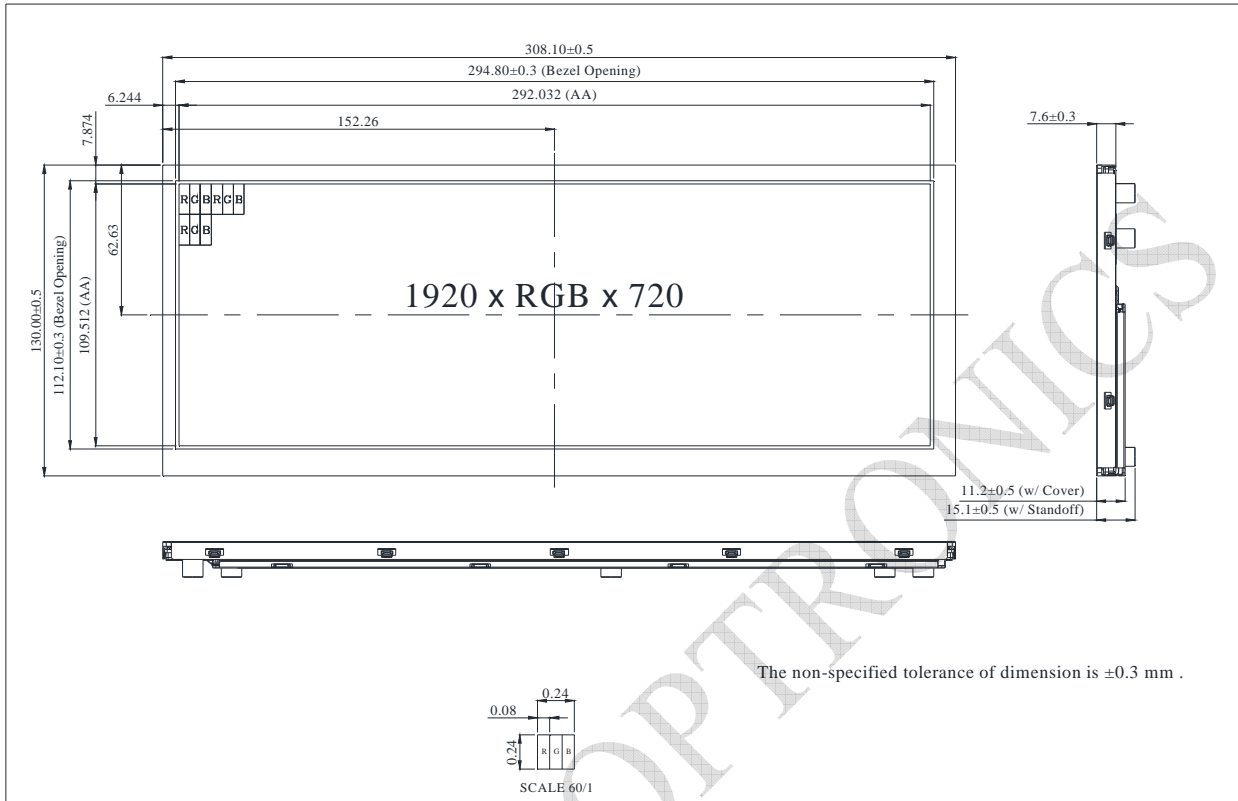

RAYSTAR OPTRONICS

CN1(F31L-1A7H1-21050)

PIN NO	SYMBOL	PIN NO	SYMBOL
1	GND	29	ERXIN3+
2	NC	30	GND
3	VCC	31	NC
4	VCC	32	RESETB
5	GND	33	STBYB
6	GND	34	CA3
7	NC	35	NC
8	NC	36	NC
9	GND	37	NC
10	ORXIN0-	38	GND
11	ORXIN0+	39	GND
12	ORXIN1-	40	NC
13	ORXIN1+	41	LEDA
14	ORXIN2-	42	LEDA
15	ORXIN2+	43	LEDA
16	ORXCLKIN-	44	NC
17	ORXCLKIN+	45	LEDK1
18	ORXIN3-	46	LEDK2
19	ORXIN3+	47	LEDK3
20	ERXIN0-	48	LEDK4
21	ERXIN0+	49	NTC_A
22	ERXIN1-	50	NTC_K
23	ERXIN1+		
24	ERXIN2-		
25	ERXIN2+		
26	ERXCLKIN-		
27	ERXCLKIN+		
28	ERXIN3-		

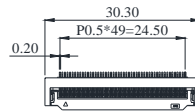
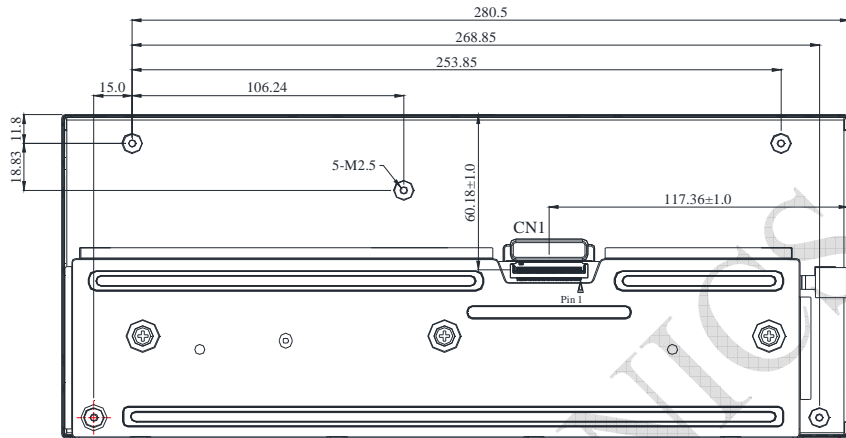

F31L-1A7H1-21050
SCALE 2/1

The non-specified tolerance of dimension is ± 0.3 mm .

RAYSTAR OPTRO

Absolute Maximum Ratings

Item	Symbol	Min	Typ	Max	Unit
Operating Temperature	TOP	-30	—	+85	°C
Storage Temperature	TST	-30	—	+85	°C

Electrical Characteristics

1. TFT LCD Module

Item	Symbol	Min	Typ	Max	Unit
Supply Voltage	VCC	3	3.3	3.6	V
Input signal voltage	ViH	VCC *0.7	-	VCC	V
	ViL	0	-	VCC *0.3	V
Current of power supply	ICC	--	--	400	mA

2. Switching Characteristics for LVDS Receiver

Item	Symbol	Min	Typ	Max	Unit	Conditions
Differential Input High Threshold	Vth	—	—	100	mV	V _{CM} =1.2V
Differential Input Low Threshold	Vtl	-100	—	—	mV	
Input Current	I _{IN}	-10	—	+10	uA	
Differential input Voltage	V _{ID}	0.2	—	0.6	V	
Common Mode Voltage Offset	V _{CM}	1	1.2	1.7-(V _{ID} /2)	V	

3. Backlight Unit

Parameter	Symbol	Min	Typ	Max	Units	Condition
LED Current	IF	--	240	--	mA	Ta=25°C
LED Voltage	VF	--	35.2	37.4	Volt	Ta=25°C
LED Life-Time	N/A	30,000	--	--	Hour	Ta=25°C IF=60mA