



# 曜凌光電股份有限公司

Web: [www.raystar-optronics.com](http://www.raystar-optronics.com) E-mail: [sales@raystar-optronics.com](mailto:sales@raystar-optronics.com)

## RFF700Q-1IW-DBN

---

### SPECIFICATION

#### General Specifications

- Size: 7.0 inch
- Dot Matrix: 800 x RGB x 480(TFT) dots
- Module dimension: 165.0(W) x 100.0(H) x 11.5(D) mm
- Active area: 154.08 x 85.92 mm
- Dot pitch: 0.0642 x 0.179 mm
- LCD type: TFT, Normally White, Transmissive
- View Direction: 12 o'clock
- Gray Scale Inversion Direction: 6 o'clock
- Backlight Type: LED, Normally White
- Controller IC: SSD1963
- Interface: Digital 8080 family MPU 8bit/16bit
- With /Without TP: Without TP
- Surface: Anti-Glare

\*Color tone slight changed by temperature and driving voltage.

## Interface

### LCM PIN Definition (CON2)

Pin	Symbol	Function
1	GND	System ground pin of the IC . Connect to system ground.
2	VDD	Power Supply : +3.3V
3	BLE	Backlight control signal , H: On \ L: Off
4	D/C	Data/Command select
5	WR	Write strobe signal
6	RD	Read strobe signal
7	DB0	Data bus
8	DB1	Data bus
9	DB2	Data bus
10	DB3	Data bus
11	DB4	Data bus
12	DB5	Data bus
13	DB6	Data bus
14	DB7	Data bus
15	DB8	Data bus (When select 8bits Mode, this pin is NC)
16	DB9	Data bus (When select 8bits Mode, this pin is NC)
17	DB10	Data bus (When select 8bits Mode, this pin is NC)
18	DB11	Data bus (When select 8bits Mode, this pin is NC)
19	DB12	Data bus (When select 8bits Mode, this pin is NC)
20	DB13	Data bus (When select 8bits Mode, this pin is NC)
21	DB14	Data bus (When select 8bits Mode, this pin is NC)
22	DB15	Data bus (When select 8bits Mode, this pin is NC)
23	NC	No connect
24	NC	No connect
25	CS	Chip select
26	RST	Hardware reset
27	L/R	Left / right selection; Default L/R=H
28	U/D	Up/down selection; ; Default U/D=L
29	NC	No connect
30	NC	No connect
31	NC	No connect
32	NC	No connect
33	VLED-	Power for LED Driver IC(GND)
34	VLED-	Power for LED Driver IC(GND)
35	VLED+	Power for LED Driver IC(+5V)
36	VLED+	Power for LED Driver IC(+5V)

# Contour Drawing

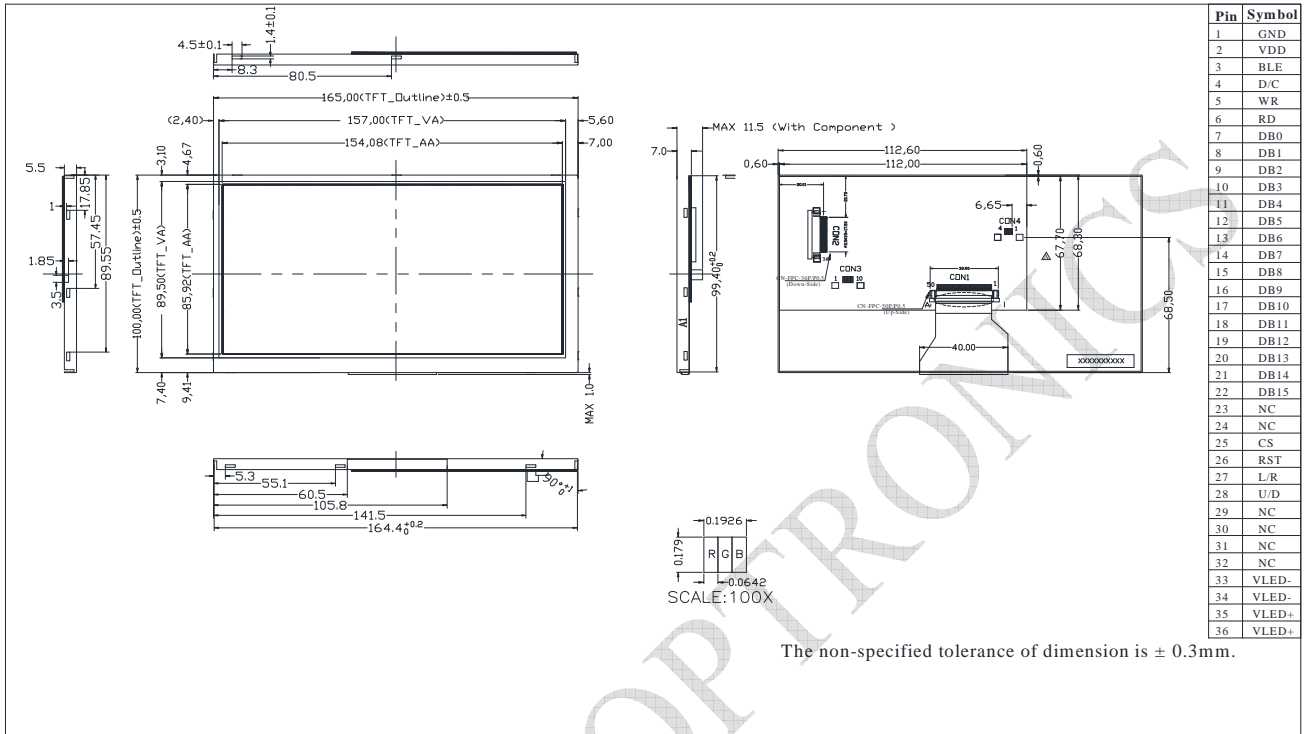

## Absolute Maximum Ratings

Item	Symbol	Min	Typ	Max	Unit
Operating Temperature	TOP	-20	—	+70	°C
Storage Temperature	TST	-30	—	+80	°C

## Electrical Characteristics

Operating conditions: (CON2.Pin1=GND, Pin2=VDD)

Item	Symbol	Condition	Min	Typ	Max	Unit
Supply Voltage For LCM	VDD	—	3.0	3.1	3.3	V
Supply Current For LCM	IDD	—	—	300	450	mA

Backlight driving conditions (CON2.Pin33,34=VLED-, Pin35,36=VLED+)

Parameter	Symbol	Min	Typ	Max	Unit
Operation Current For LED Driver	VLED=5V	400	—	600	mA
Power Consumption	VLED=5V	2000	—	3000	mW
Supply Voltage For LED Driver	VLED+	—	5	—	V
LED Life Time	—	—	50,000	—	Hr