



**RAYSTAR**

**曜凌光電股份有限公司**

Web: [www.raystar-optronics.com](http://www.raystar-optronics.com) E-mail: [sales@raystar-optronics.com](mailto:sales@raystar-optronics.com)

## **RFF700G-AIW-DNS**

---

### **SPECIFICATION**

#### **General Specifications**

- Size: 7.0 inch
- Dot Matrix: 800 x RGB x 480(TFT)
- Module dimension: 165.0(W) x 100(H) x 7.0(D) mm
- Active area: 154.08 x 85.92 mm
- Dot pitch: 0.0642 x 0.179 mm
- LCD type: TFT, Normally White, Transmissive
- View Direction: 12 o'clock
- Gray Scale Inversion Direction: 6 o'clock
- Backlight Type: LED, Normally White
- With /Without TP: With RTP
- Surface: Anti-Glare

\*Color tone slight changed by temperature and driving voltage.

## Interface

### LCM PIN Definition

Pin	Symbol	Function
1	A	Power supply for backlight
2	A	Power supply for backlight
3	K	Backlight ground
4	K	Backlight ground
5	GND	Power ground
6	VCOM	Common voltage
7	VCC	Power for Digital Circuit
8	MODE	DE/SYNC mode select
9	DE	Data Input Enable
10	VS	Vertical Sync Input
11	HS	Horizontal Sync Input
12	B7	Blue data(MSB)
13	B6	Blue data
14	B5	Blue data
15	B4	Blue data
16	B3	Blue data
17	B2	Blue data
18	B1	Blue data
19	B0	Blue data(LSB)
20	G7	Green data(MSB)
21	G6	Green data
22	G5	Green data
23	G4	Green data
24	G3	Green data
25	G2	Green data
26	G1	Green data
27	G0	Green data(LSB)
28	R7	Red data(MSB)
29	R6	Red data
30	R5	Red data
31	R4	Red data
32	R3	Red data
33	R2	Red data
34	R1	Red data
35	R0	Red data(LSB)
36	GND	Power Ground
37	DCLK	Sample clock
38	GND	Power Ground
39	L/R	Left / right selection
40	U/D	Up/down selection
41	VGH	Gate ON Voltage
42	VGL	Gate OFF Voltage
43	AVDD	Power for Analog Circuit

44	RESET	Global reset pin.
45	NC	No connection
46	VCOM	Common Voltage
47	DITHB	Dithering function
48	GND	Power Ground
49	NC	No connection
50	NC	No connection

### Contour Drawing

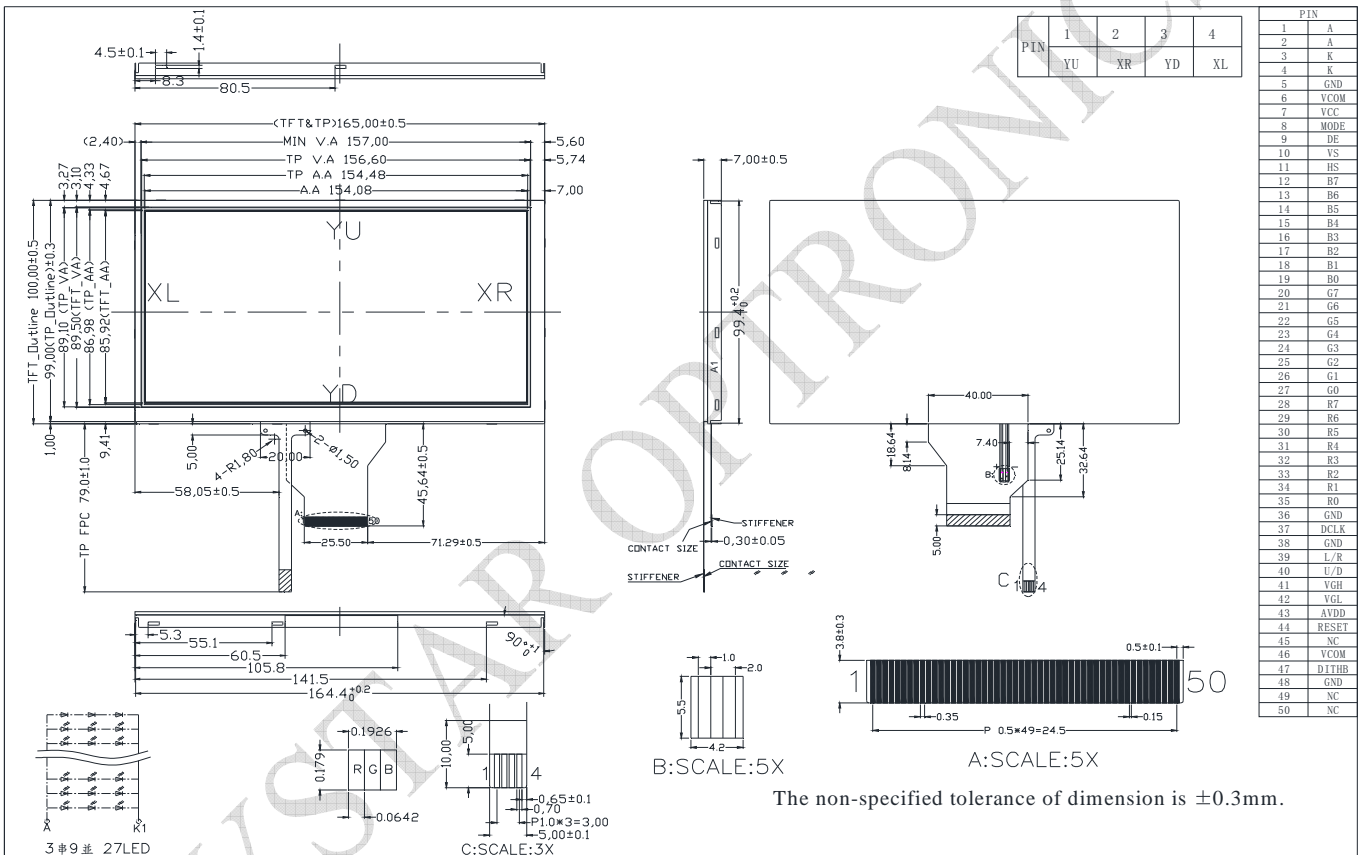

## Absolute Maximum Ratings

Item	Symbol	Min	Typ	Max	Unit
Operating Temperature	TOP	-20	—	+70	°C
Storage Temperature	TST	-30	—	+80	°C

## Electrical Characteristics

### Operating conditions

Item	Symbol	Min	Typ	Max	Unit
Supply Voltage For Logic	VCC	3.0	3.3	3.6	V
Power Supply For Current	VCC =3.3V		4	10	mA
Power Consumption	VCC =3.3V		13.2	36	mW
Power voltage	AVDD	10.2	10.4	10.6	V
Power voltage	VGH	15.3	16.0	16.7	V
Power voltage	VGL	-7.7	-7.0	-6.3	V
Input signal voltage	VCOM	2.6	(3.6)	4.6	V

### LED driving conditions

Parameter	Symbol	Min	Typ	Max	Unit
LED current	-	-	180	-	mA
Power Consumption	-	1620	-	1890	mW
LED voltage	A~K	9.0	-	10.5	V
LED Life Time	-	-	50,000	-	Hr