

OLED DISPLAY SPECIFICATION



RAYSTAR

RAYSTAR Optronics, Inc.
曜凌光電股份有限公司



曜凌光電股份有限公司
Raystar Optronics, Inc.

T: +886-4-2565-0761 | F: +886-4-2565-0760
sales@raystar-optronics.com | www.raystar-optronics.com

SPECIFICATION

Model No:
REX009616B

General Specification

The Features is described as follow:

- Module dimension: 26.3 × 8.0 × 1.26 mm
- Active area: 17.26 × 3.18mm
- Dot Matrix: 96*16
- Pixel Size: 0.16 × 0.18 mm
- Pixel Pitch: 0.18 × 0.20 mm
- Duty: 1/16 Duty
- Display Mode : Passive Matrix
- Display Color: OLED , Monochrome
- IC: SSD1306
- Interface: I2C
- Size: 0.69 inch

Interface Pin Function

No.	Symbol	Function
1	C2N	C1P/C1N – Pin for charge pump capacitor; Connect to each other with a capacitor. C2P/C2N – Pin for charge pump capacitor; Connect to each other with a capacitor.
2	C2P	
3	C1P	
4	C1N	
5	VBAT	This is the power supply pin for the internal buffer of the DC/DC voltage converter. It must be connected to external source when the converter is used. It should be connected to VDD when the converter is not used.
6	NC	No connection
7	VSS	This is a ground pin.
8	VDD	Power supply pin for core logic operation.
9	RES#	This pin is reset signal input. When the pin is low, initialization of the chip is executed. Keep this pin HIGH (i.e. connect to VDD) during normal operation.
10	SCL	When I2C mode is selected, D2, D1 should be tied together and serve as SDAout, SDAin in application and D0 is the serial clock input, SCL.
11	SDA	
12	IREF	This pin is segment current reference pin. A resistor should be connected between this pin and VSS. Set the current lower than 30uA. When internal IREF is used, this pin should be kept NC.
13	VCOMH	The pin for COM signal deselected voltage level. A capacitor should be connected between this pin and VSS.
14	VCC	This is the most positive voltage supply pin of the chip. A stabilization capacitor should be connected between this pin and VSS when the converter is used. It must be connected to external source when the converter is not used.

Contour Drawing & Block Diagram

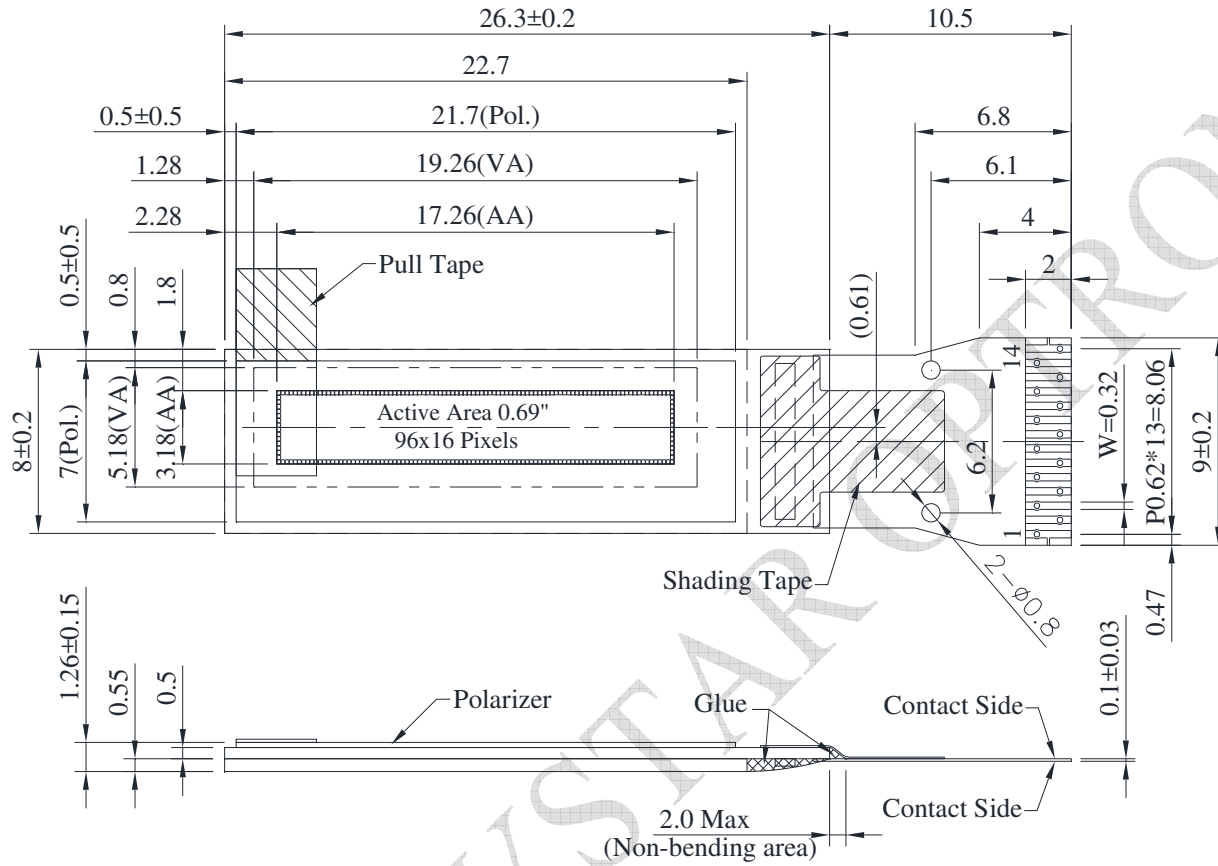

PIN	SYMBOL
1	C2N
2	C2P
3	C1P
4	C1N
5	VBAT
6	NC
7	VSS
8	VDD
9	RES#
10	SCL
11	SDA
12	IREF
13	VCOMH
14	VCC

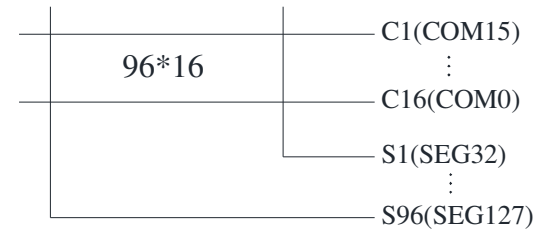

The non-specified tolerance of dimension is ± 0.3 mm .

Absolute Maximum Ratings

Parameter	Symbol	Min	Max	Unit
Supply Voltage for Logic	VDD	0	4.0	V
Supply Voltage for Display	VCC	0	16.0	V
Charge Pump Regulator Supply Voltage	VBAT	0	5	V
Operating Temperature	TOP	-30	+70	°C
Storage Temperature	TSTG	-30	+70	°C

Electrical Characteristics

DC Electrical Characteristics

Item	Symbol	Condition	Min	Typ	Max	Unit
Supply Voltage for Logic	VDD	—	1.65	3.0	3.3	V
Supply Voltage for Display (Supplied Externally)	VCC	—	6.0	7.5	8.0	V
Charge Pump Regulator Supply Voltage	VBAT	—	3.0	—	4.2	V
Charge Pump Output Voltage for Display (Generated by Internal DC/DC)	Charge Pump VCC	—	7.0	7.5	—	V
Input High Volt.	VIH	—	0.8×VDD	—	VDD	V
Input Low Volt.	VIL	—	0	—	0.2×VDD	V
Output High Volt.	VOH	—	0.9×VDD	—	VDD	V
Output Low Volt.	VOL	—	0	—	0.1×VDD	V
50% checkerboard operating Current (VCC Supplied Externally)	ICC	—	—	5	10	mA
50% checkerboard operating Current (VCC Generated by Internal DC/DC)	IBAT	—	—	5	10	mA